



The rechargeable batteries are lead-lead dioxide systems. The dilute sulfuric acid electrolyte is absorbed by separators and plates and thus immobilized. Should the battery be accidentally overcharged producing hydrogen and oxygen, special one-way valves allow the gases to escape thus avoiding excessive pressure build-up. Otherwise, the battery is completely sealed and is, therefore, maintenance-free, leak proof and usable in any position.

Battery Construction

Component	Positive plate	Negative plate	Container	Cover	Safety valve	Terminal	Separator	Electrolyte
Raw material	Lead dioxide	Lead	ABS	ABS	Rubber	Pb	Fiberglass	Sulfuric acid

General Features

- Absorbent Glass Mat (AGM) technology for efficient gas recombination of up to 99% and freedom from electrolyte maintenance or water adding.
- Not restricted for air transport-complies with IATA/ICAO Special Provision A67.
- UL-recognized component.
- Can be mounted in any orientation.
- Computer designed lead, calcium tin alloy grid for high power density.
- Long service life, float or cyclic applications.
- Maintenance-free operation.
- Low self discharge.

Dimensions and Weight

Length(mm / inch)	229 / 9.01
Width(mm / inch)	138 / 5.43
Height(mm / inch)	208 / 8.18
Total Height(mm / inch)	213 / 8.38
Approx. Weight(Kg / lbs)	18.0 / 39.7

* Weight deviation: ± 3%

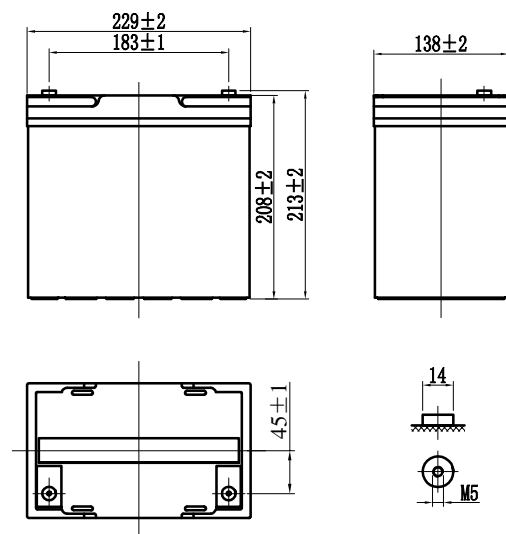

Performance Characteristics

Nominal Voltage	12V
Number of cell	6
Design Life	10 years
Nominal Capacity 77°F(25°C)	
10 hour rate (5.13A, 10.8V)	51.3Ah
5 hour rate (9.13A, 10.5V)	45.65Ah
1 hour rate (34.6A, 9.6V)	34.6Ah
Internal Resistance	
Fully Charged battery 77°F(25°C)	≤ 7.2mOhms
Self-Discharge	
3% of capacity declined per month at 20°C(average)	
Operating Temperature Range	
Discharge	-20~60°C
Charge	-10~60°C
Storage	-20~60°C
Max. Discharge Current 77°F(25°C)	550A(5s)
Short Circuit Current	1400A
Charge Methods: Constant Voltage Charge 77°F(25°C)	
Cycle use	2.40-2.45VPC
Maximum charging current	16.5A
Temperature compensation	-30mV/°C
Standby use	2.20-2.30VPC
Temperature compensation	-20mV/°C

Discharge Constant Current (Amperes at 77°F25°C)

End Point Volts/Cell	5min	10min	15min	30min	1h	3h	5h	10h	20h
1.60V	172	127	97.4	58.2	34.6	14.4	9.72	5.33	2.76
1.65V	162	122	93.4	56.4	33.7	14.0	9.47	5.28	2.76
1.70V	152	113	88.6	54.6	32.8	13.7	9.30	5.23	2.76
1.75V	142	104	83.8	52.8	32.0	13.4	9.13	5.18	2.75
1.80V	131	97.8	77.5	50.9	31.2	13.1	8.96	5.13	2.75

Discharge Constant Power (Watts at 77°F25°C)

End Point Volts/Cell	5min	10min	15min	30min	45min	1h	2h	3h	5h
1.60V	313	233	181	109	83.9	67.9	40.6	28.8	18.6
1.65V	295	220	173	107	82.5	66.3	39.7	28.2	18.4
1.70V	276	213	165	105	80.8	64.8	38.9	27.6	18.0
1.75V	256	195	158	103	79.0	63.3	37.9	27.0	17.8
1.80V	243	181	150	102	76.9	62.6	36.9	26.4	17.7

(Note)The above characteristics data are average values obtained within three charge/discharge cycles not the minimum values. All data shall be changed without notice, Vision reserves the right to explain and update the information contained hereinto.

